



Installation instructions

Akrapovič Exhaust System:
Slip-On and Evolution
for the
BMW M6 (type E63, E64)

WARNING

Please note that certain aftermarket exhaust systems may not comply with applicable California laws and regulations, and may therefore be prohibited for use on California highways or roads, or on roads or vehicles otherwise subject to emissions control requirements.

Akrapovič exhaust systems for automobiles and motorcycles mounted downstream of the catalytic converter (also known as “cat-back systems”) are considered “replacement parts” in California by the California Air Resources Board (CARB), and do not require an exemption or executive order from CARB to be sold in California. However, California prohibits the use of any aftermarket exhaust system that modifies, removes or replaces original equipment catalysts, unless CARB has issued an Executive Order as to such part or system.

Further, Akrapovič parts or exhaust systems used or intended for use on “racing vehicles” (i.e. a competition vehicle used exclusively for competition on closed-course circuits) do not require an exemption or Executive Order from CARB to be sold in California. However, such parts are prohibited from use on California public highways or roads, even if occasionally used “off-road.”



Installation instructions

Akrapovič Exhaust System:
Slip-On and Evolution
for the
BMW M6 (type E63, E64)

Congratulations on purchasing an Akrapovič exhaust system. Please read the entire installation manual prior to undertaking any activities related to installation of your new Akrapovič exhaust system. In case you do not fully understand the manual or any of its parts, please contact your authorized dealer!

This product should be installed by someone with sufficient knowledge of exhaust systems and their installation, and appropriate hand or power tools. If you are not qualified for this work, please utilize a certified mechanic for installation. By installing Your Akrapovič exhaust system, you indicate that you have read the installation manual in its entirety and you agree with the terms stated herein.

It is your responsibility to follow all installation instruction guidelines supplied with the Akrapovič exhaust system and undertake all necessary safety precautions. Akrapovič d.d. assumes no responsibility for damages occurring from misuse, abuse, improper installation, improper operation, lack of responsible care, or all previously stated reasons resulting from incompatibility with other manufacturer's products and/or systems.

IMPORTANT INFORMATION

Exclusion of Certain Liability

1. The manufacturer, importer or dealer shall not be liable for any incidental damage including personal injury or any other damages caused by improper installation or operation of the Akrapovič exhaust system. When installing the Akrapovič exhaust system be careful that the exhaust system does not touch other parts sensitive to high temperature.
2. Akrapovič makes no representation or warranties with regard to damage caused by the improper installation, use and maintenance of the Akrapovič exhaust system. The warranty is limited to defects recognized by our technical department and due to normal use, and excludes items subject to normal wear (gaskets and damping wool). The guarantee is void in case of accident, modification, improper or competition use.
3. Do not attempt to install the Akrapovič exhaust system on a vehicle model for which it was not made or tested by Akrapovič.
4. When the exhaust system gets very hot during operation, be careful not to burn yourself on the exhaust system or parts which are in direct contact with it, even when the engine is not running. Also protect other people, especially children, from the injuries mentioned above.

1. In some cases Akrapovič exhaust system kits contain chemical products (ceramic anti-seizing grease; bolt sealant). Handle with care, do not inhale or swallow. Avoid excessive contact with skin, eyes or mucous membranes. Keep out of reach of children.
2. Technical specifications of Akrapovič exhaust systems and related products are subject to change without notice.
3. Before removing the original exhaust system from your vehicle, please compare the parts you received with the list of materials provided in the installation manual in order to assure that you have all the parts necessary for the installation of your new Akrapovič exhaust system.
4. Although this manual consists of instructions for installation in written form, as well as photographs and pictures representing individual steps of the installation, please note that the photographs and pictures are symbolic and are intended for representation of general overview only. The photographs and pictures contained herein should serve as a guideline only and actual installation of the exhaust system may not correspond with the photographs and pictures entirely.
5. The process of uninstalling the original exhaust system may vary depending on the existing exhaust system. Please follow the original exhaust system manufacturer's instructions for uninstalling the original exhaust system.

Trademarks

The Akrapovič Exhaust System Technology logo is a registered trademark of Akrapovič d.d.

Akrapovič website

Information about Akrapovič exhaust systems and related products is available on the Akrapovič website at:

<http://www.akrapovic.com/>

Copyright

No part of the Akrapovič exhaust system or its documentation may be reproduced or distributed in any form or by any means without the prior written authorization of the Akrapovič company.

© Akrapovič, d.d. All rights reserved.

Symbols

The following symbols are used throughout these installation instructions:



TOOLS REQUIRED



TIGHTENING TORQUE



INSTALLATION TIP



CAUTION OR WARNING



USE BOLT SEALANT; Apply 3 to 4 small drops of bolt sealant onto the cleaned and degreased threads before tightening the bolts. **WARNING! Avoid contact with skin, eyes and mucous membranes. Do not inhale fumes. Keep out of the reach of children.**



USE ANTI-SEIZE LEAD-FREE COPPER PASTE (black tube); Provides trouble-free and long-lasting protection against seizing, corrosion and rusting of bolts, threaded ends, nuts, joints, etc. Also protects against vibration, wear and impact. **WARNING! Avoid eye contact. Avoid excessive skin contact. Keep out of reach of children.**



USE ANTI-SEIZING GREASE (white tube); Prevents seizing, corrosion and excessive wear between the titanium components of your exhaust system. **WARNING! Avoid eye contact. Avoid excessive skin contact. Keep out of reach of children.**



T-handle swiveling CTX E12 wrench
T-handle swiveling 13 mm wrench
Combination 13 mm wrench



BEFORE INSTALLING, CHECK THE SCHEMATIC OF THE EXHAUST SYSTEM!



IF ANY ITEMS IN THE AKRAPOVIČ EXHAUST SYSTEM PACKAGE ARE MISSING, PLEASE CONTACT YOUR AUTHORIZED DEALER. KEEP THE SCHEMATIC FOR FUTURE REFERENCE.



THESE INSTALLATION INSTRUCTIONS MUST BE READ CAREFULLY IN ORDER TO ENSURE PROPER INSTALLATION AND OPERATION OF THE AKRAPOVIČ EXHAUST SYSTEM.



THE EXHAUST SYSTEM CAN BE EXTREMELY HOT. ALLOW THE EXHAUST AND ENGINE TO COOL DOWN BEFORE BEGINNING INSTALLATION.



WE ADVISE YOU TO LEAVE INSTALLATION TO A QUALIFIED SERVICEMAN. IMPROPER INSTALLATION MAY RESULT IN A SHORTER LIFETIME OF THE EXHAUST SYSTEM AND/OR DAMAGE TO THE VEHICLE.

REMOVAL OF STOCK EXHAUST SYSTEM:

Put the vehicle onto a car lift.

! **WARNING:** make sure, that car lifting is safely and correctly done or you risk vehicle damage, injury or even death!

1. For Slip-On and Evolution: unscrew the marked M8 bolts and nuts from stock header flanges (**Figure 1**).

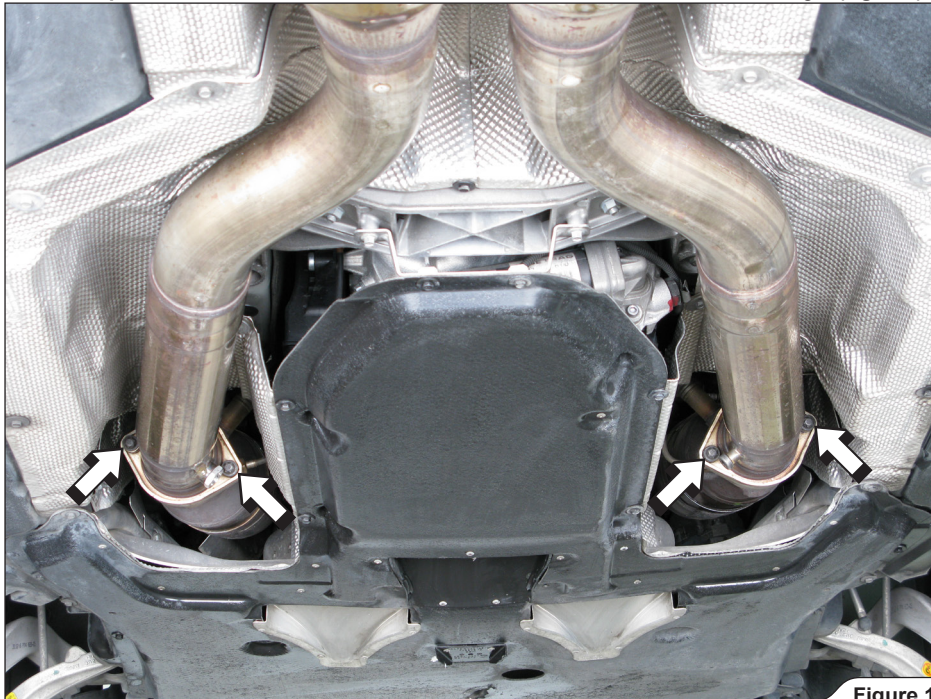

Figure 1

2. **For Slip-On and Evolution:** unscrew the marked bolts and nuts (**Figure 2**). Remove the aluminium exhaust bracket off the vehicle.

! **WARNING:** make sure, that stock exhaust is supported during removal!

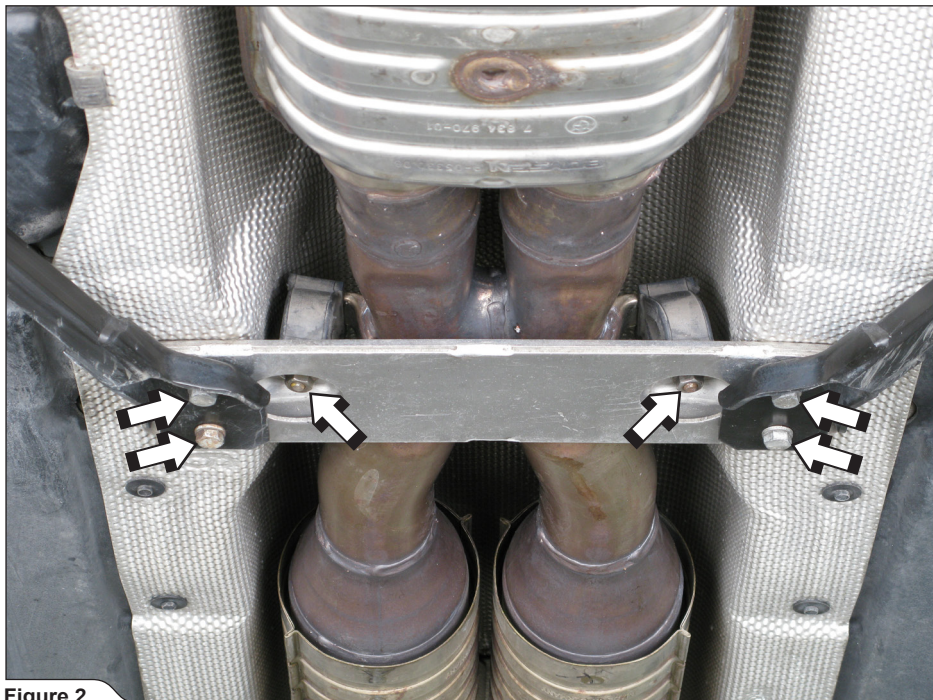

Figure 2

3. **For Slip-On and Evolution:** unscrew the marked rubber bracket nuts on both sides of the vehicle (Figure 3).

! **WARNING:** make sure, that stock exhaust is supported during removal!

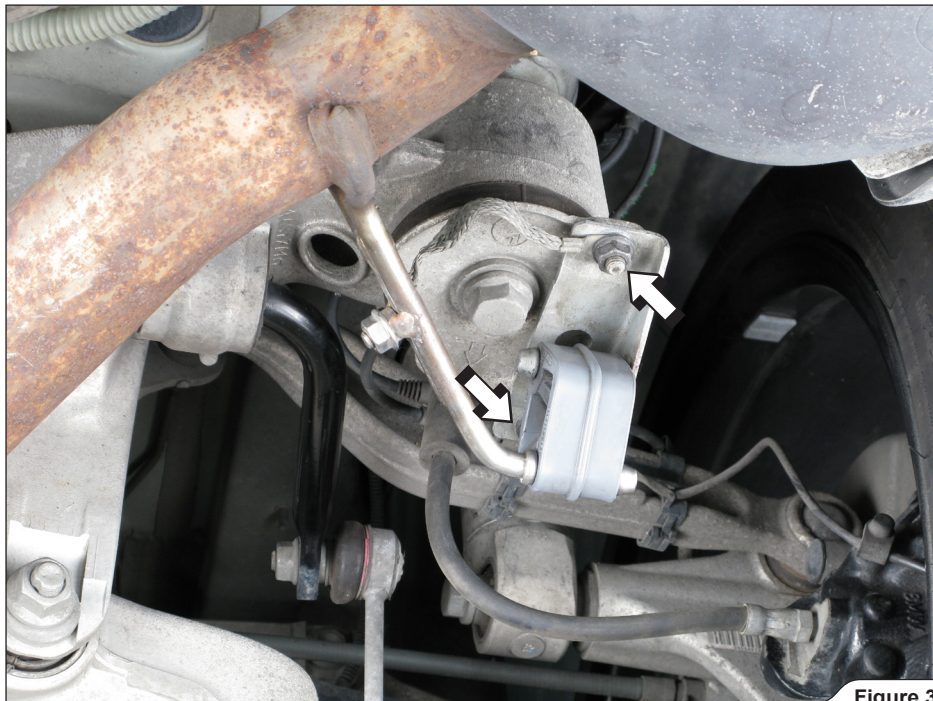

Figure 3

4. **For Slip-On and Evolution:** unscrew the marked rubber bracket nuts on both sides of the vehicle and remove the stock exhaust system off the vehicle (**Figure 4**).
- ! **WARNING:** make sure, that you don't damage any part of the vehicle or injure yourself during removal!

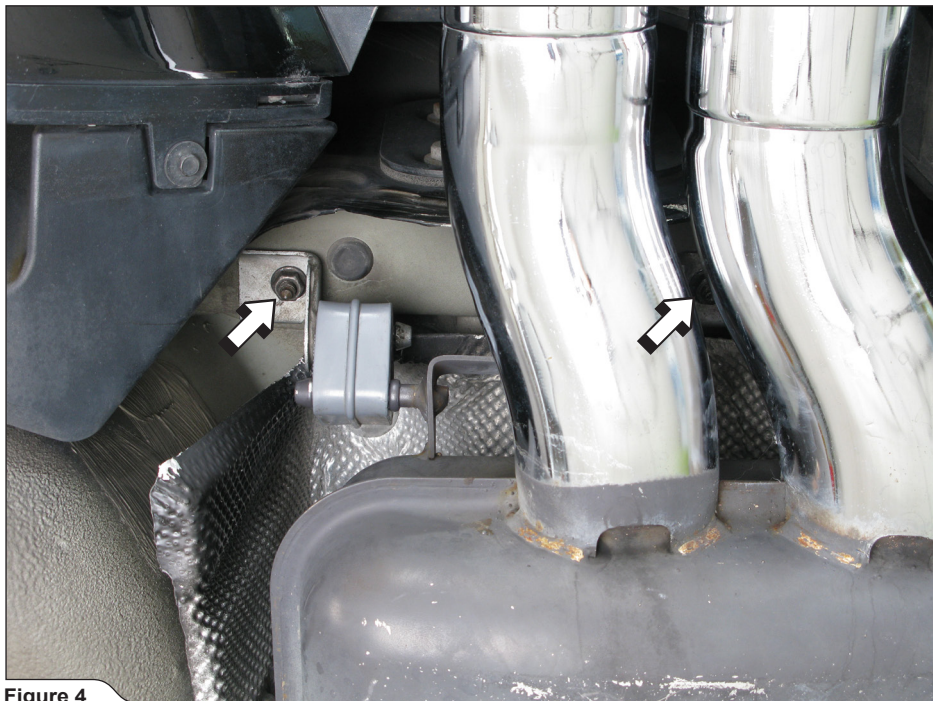

Figure 4

5. **For Slip-On only:** mark stock middle pipes looking from under the vehicle in direction of driving; **LEFT pipe: 150mm(5.9in)**, **RIGHT pipe: 130mm(5.12in)** from the end of the inner radius of the bends of the pipes, as shown in figures. Cut both pipes with angle grinder or equivalent (**Figure 5, 6**).

! **WARNING:** make sure, that you don't injure yourself during cutting process! Use personal protection equipment!

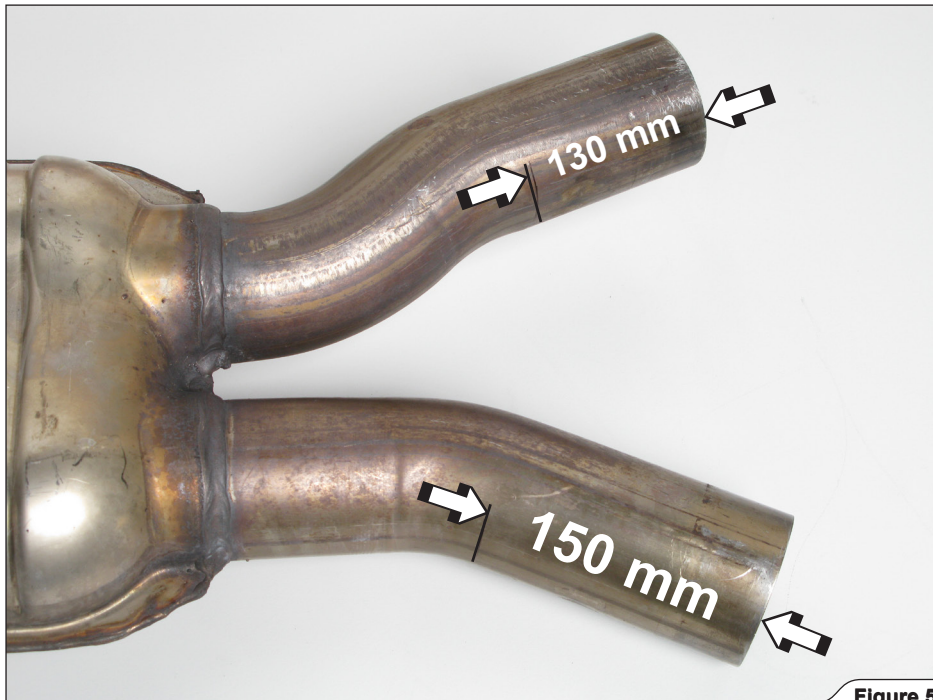

Figure 5

6. **For Slip-On only:** reinstall the front part of stock exhaust system in the reverse order from the order in which it was removed. Check vehicle manufacturer manual for tightening torques.

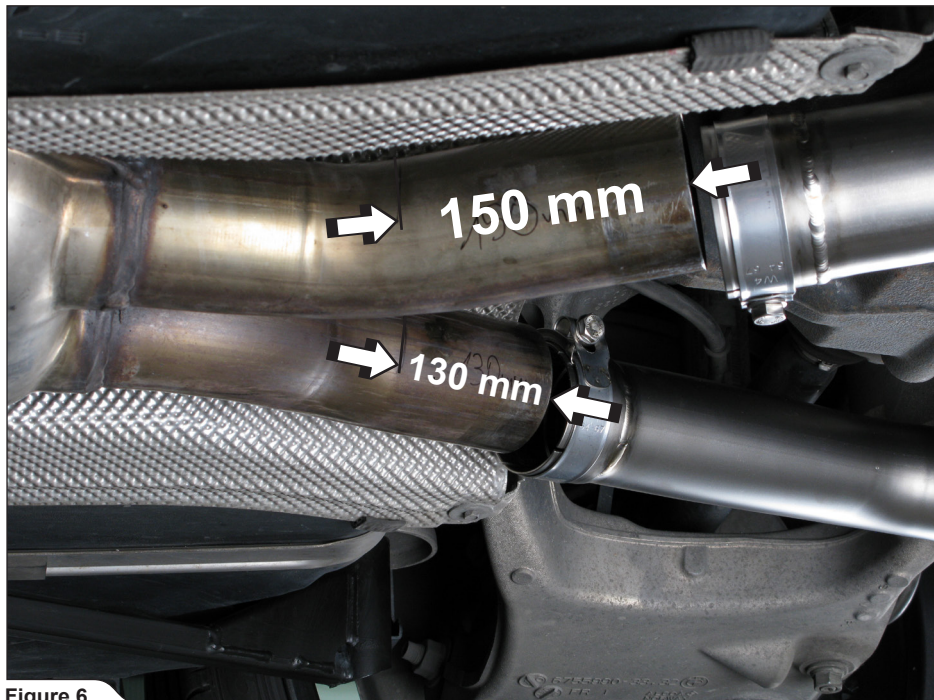
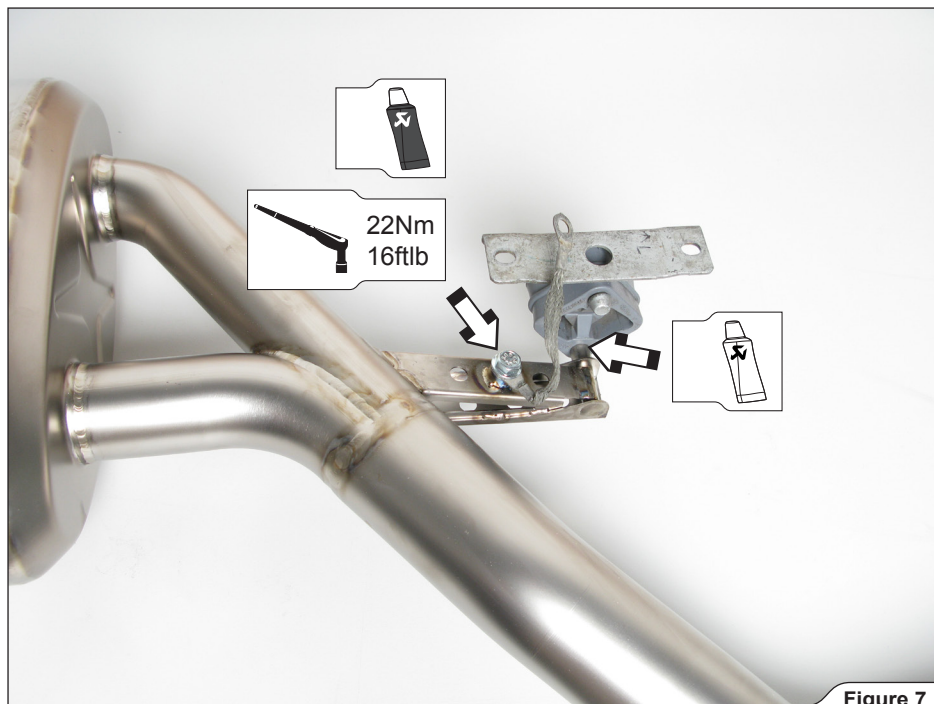

Figure 6

INSTALLATION OF THE AKRAPOVIČ EXHAUST SYSTEMS:

1. **For Slip-On and Evolution:** attach the stock rubber muffler brackets (bear in mind, that brackets are not simetrical) and ground wires (using Akrapovič M8x16mm bolts) on both Akrapovič mufflers (**Figure 7, 8**).



✂ **INSTALLATION TIP:** for easier mounting, lubricate the stock rubber brackets with ceramic grease (white tube).

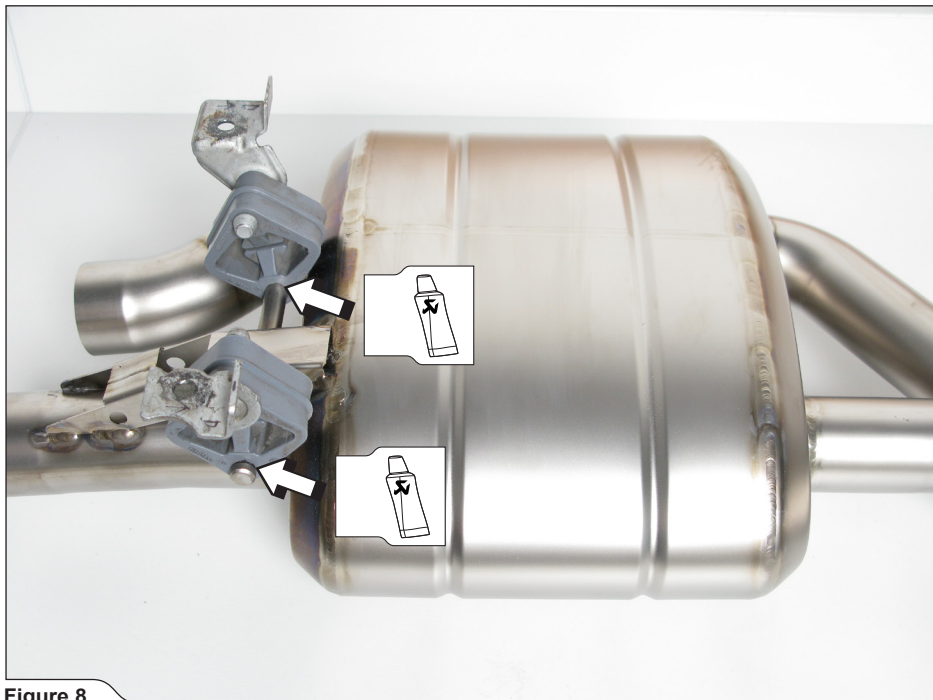

Figure 8

2. **For Slip-On and Evolution:** attach additional metal clamps to Akrapovič muffler pipes (**Figure 9**).

! **WARNING:** use anti-seize copper paste on both clamp bolt threads!

✂ **INSTALLATION TIP:** coat the interior of the inlet bushes of the muffler pipes with ceramic grease (white tube).



Figure 9

3. **For Evolution:** attach the stock bracket and additional metal clamps to Akrapovič middle pipes (Figure 10).

! **WARNING:** use anti-seize copper paste on nuts threads (especially on both clamp bolts)!

⚡ **INSTALLATION TIP:** coat the interior of the inlet bushes of the middle pipes with ceramic grease (white tube).

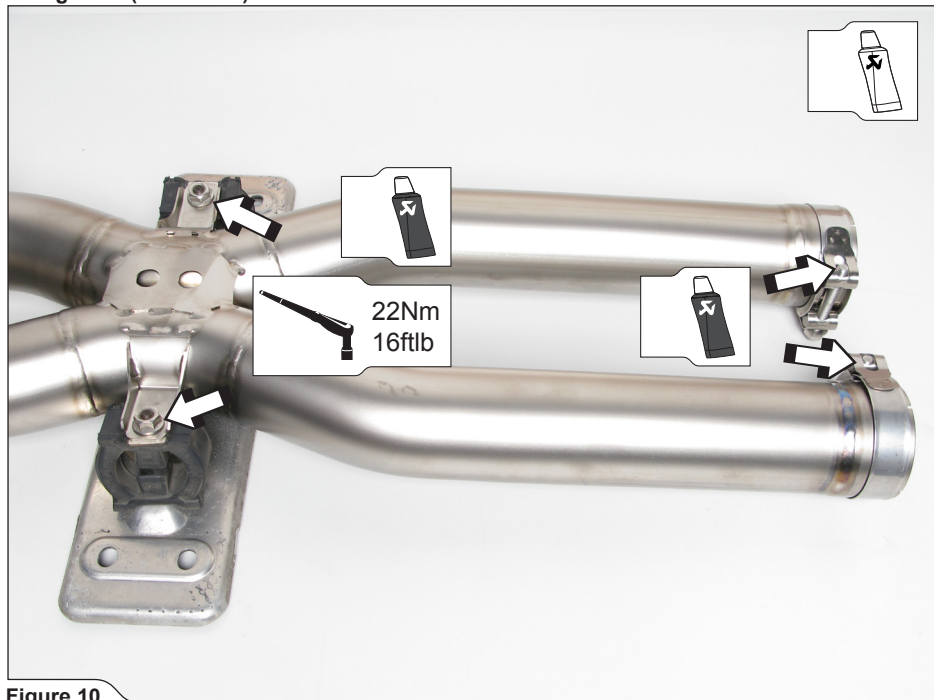

Figure 10

4. **For Evolution:** assemble the Akrapović front pipes on the stock header pipes using stock bolts and nuts (Figure 11).
- ! **CAUTION:** use new exhaust gaskets in Akrapović front pipes - stock header pipes joints!
- ! **WARNING:** use anti-seize copper paste on bolt and nut threads!
- ✂ **INSTALLATION TIP:** coat the interior of the inlet bush of the front pipes cross connection with ceramic grease (white tube).

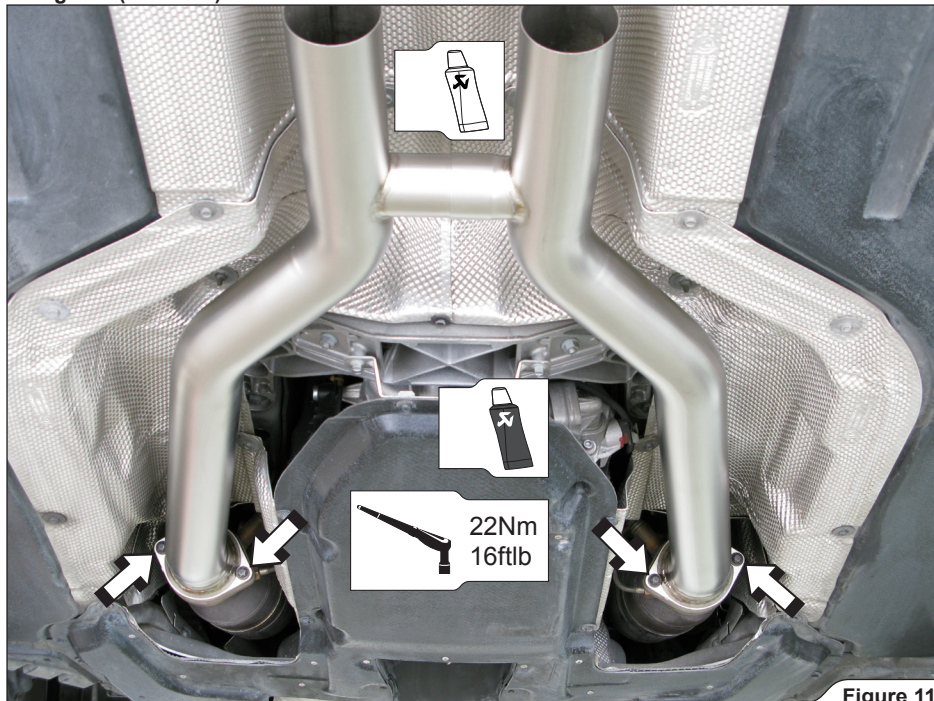

Figure 11

5. **For Evolution:** slide the middle pipes all the way onto the front pipes and tighten the stock bracket and clamps to a specified torque (**Figure 12**).

! **WARNING:** use anti-seize copper paste on all bolt threads!

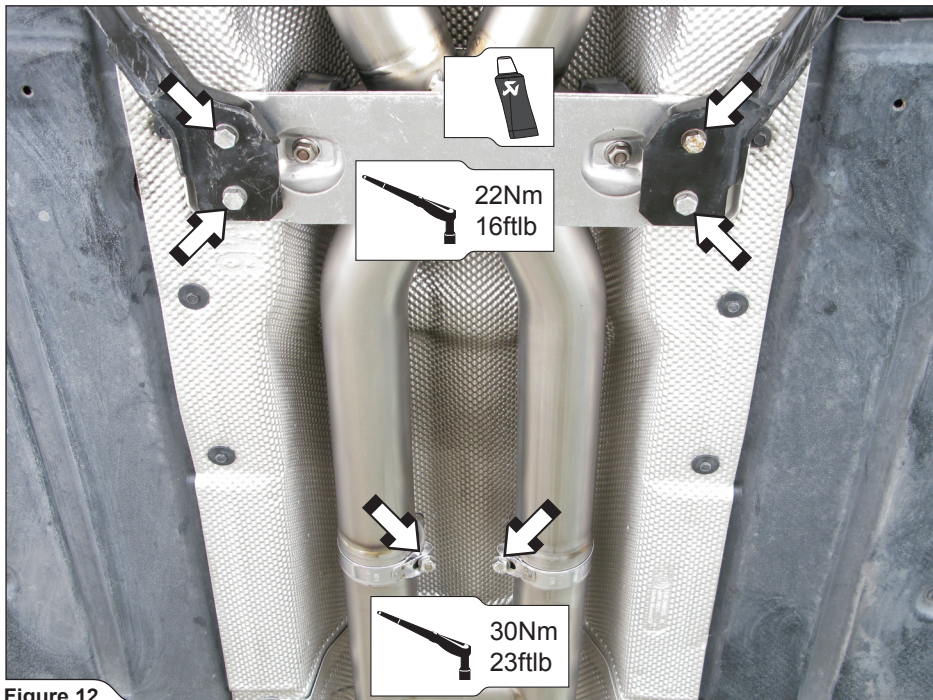

Figure 12

6. **For Slip-On and Evolution:** slide both Akrapovič mufflers onto the middle pipes and tighten the stock rubber brackets to a specified torque (**Figure 13, 14**).

! **WARNING:** use anti-seize copper paste on all nut threads!

! **WARNING:** attach the stock ground wires on both sides of the vehicle, as shown in Figure 13!

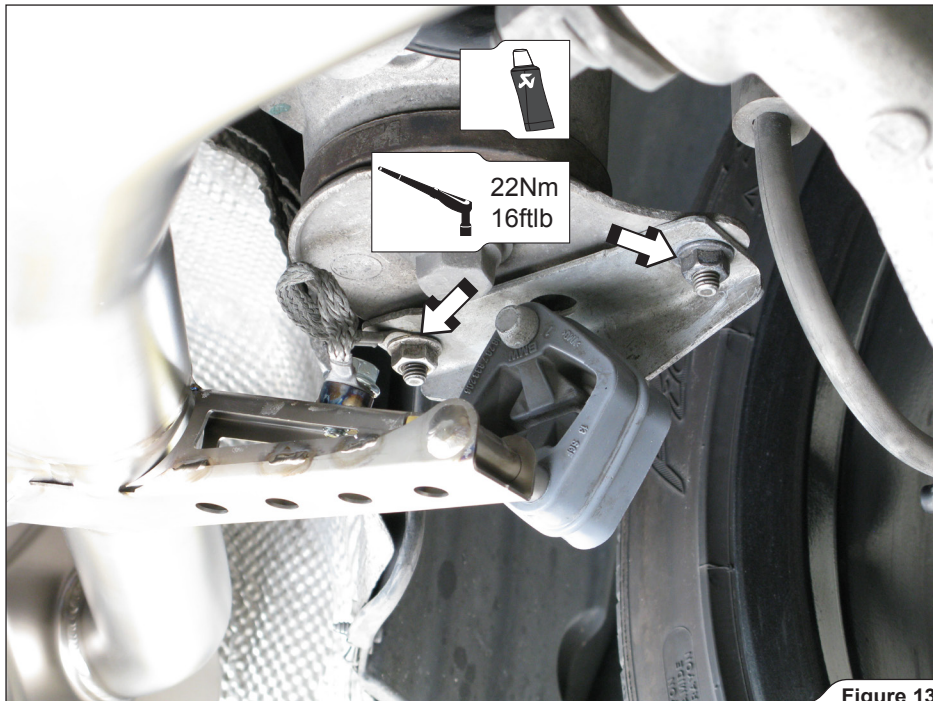

Figure 13

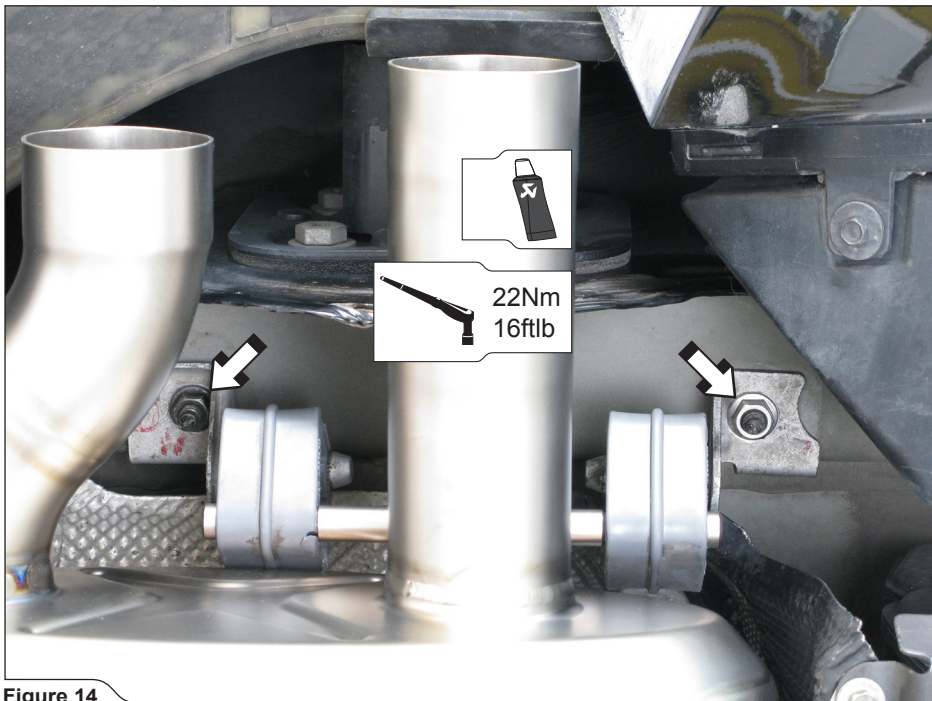

Figure 14

7. **For Evolution:** slide the muffler pipes all the way onto the Akrapovič middle pipes and tighten the clamps to a specified torque (**Figure 15**).

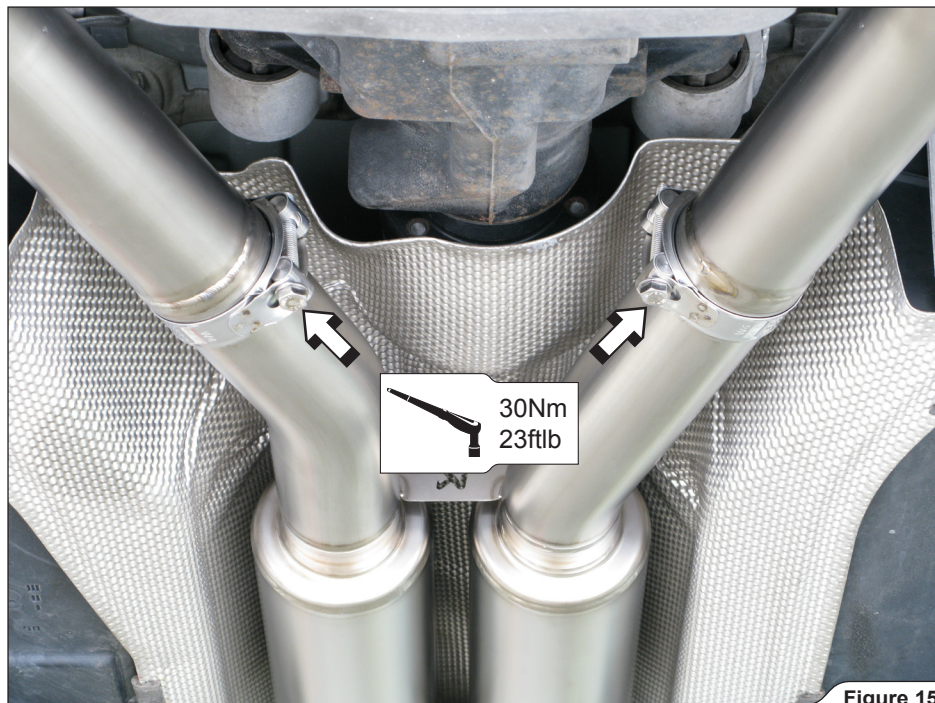

Figure 15

8. **For Slip-on:** slide the muffler pipes bushes all the way onto the stock middle pipes and tighten the clamps to a specified torque (**Figure 16**).

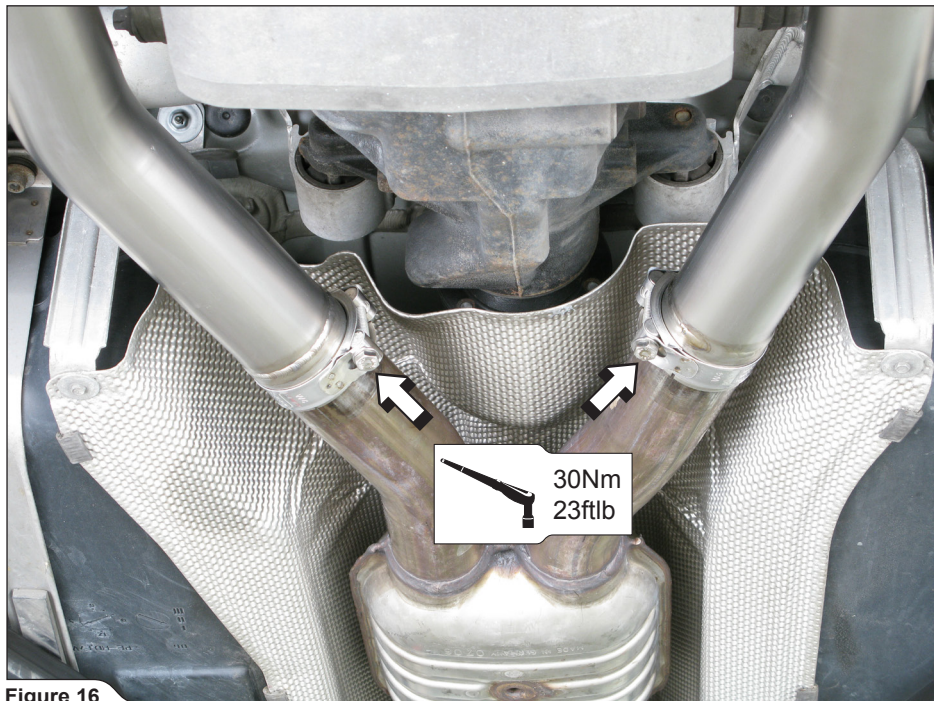

Figure 16

9. **For Slip-On and Evolution:** assemble the clamps and spherical rings onto the Tail Pipes as shown (Figure 17).

! **WARNING:** use anti-seize copper paste on clamp bolt threads!



Figure 17

10. **For Slip-On and Evolution:** slide the Akrapovič Tail-Pipes onto the muffler outlets. Center them in respect to vehicle rear bumper as shown (**Figure 18**).

✚ INSTALLATION TIP: coat the interior of the inlet bushes of the Tail Pipes with ceramic grease (white tube).

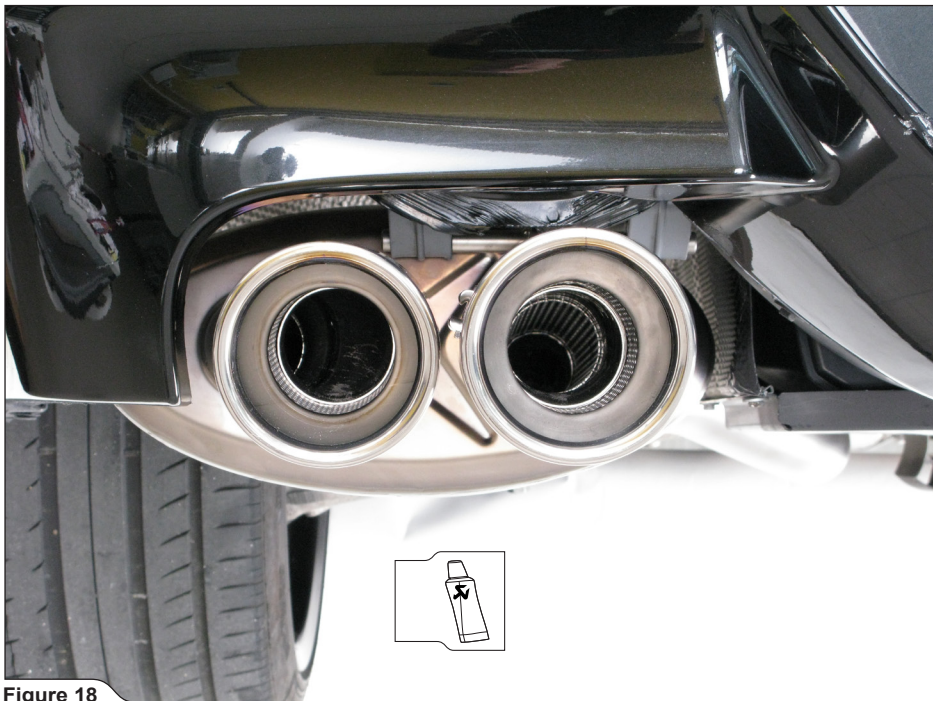

Figure 18

11. **For Slip-On and Evolution:** tighten the Tail Pipe clamps to a specified torque (**Figure 19**).

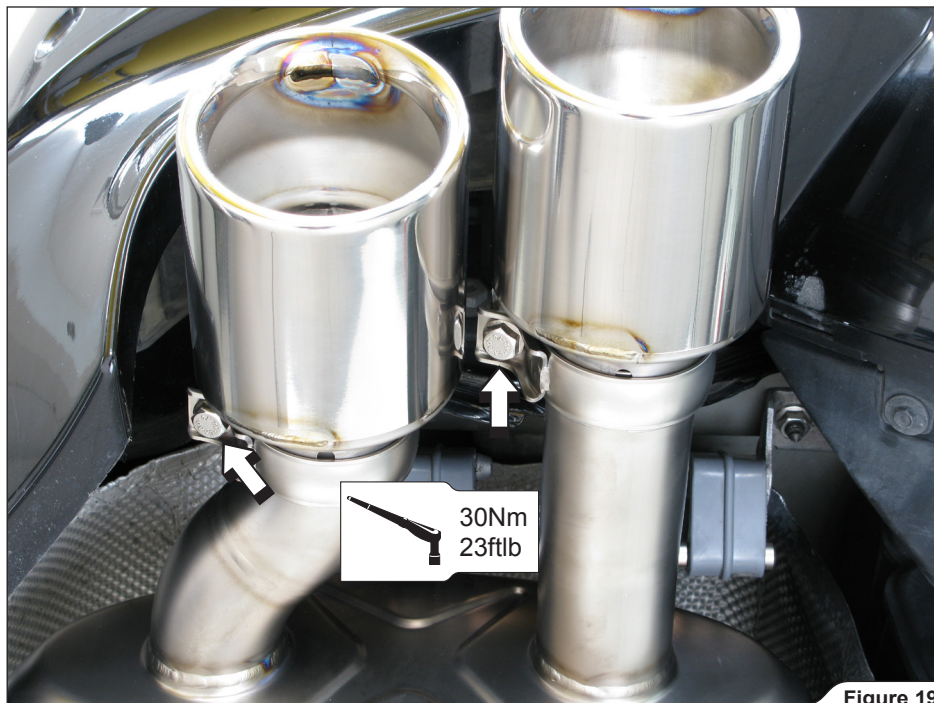

Figure 19

Final installation:

- ! **WARNING: check vehicle manufacturer manual for tightening torques (for dismantled stock parts)!**
- ! **WARNING: make sure all the nuts and bolts are sufficiently tightened. In case the exhaust system touches the cowling or other parts, repeat the adjustment of the exhaust system or contact your authorized dealer.**

MAINTENANCE OF THE AKRAPOVIČ EXHAUST SYSTEM

1. Clean the titanium exhaust components with a multi-purpose spray lubricant (WD-40 or equivalent), carbon fiber exhaust components with soft and dry cloth and stainless steel components with soft cloth sprayed with contact cleaner, then wipe with soft and dry cloth. A change in the color of the exhaust system is normal due to high temperatures.
2. Periodically make sure all the bolts and springs are sufficiently tight.

- ! **WARNING: clean all exhaust components before the first start of the engine or the stains will burn onto the surfaces!**
- ! **IT IS NORMAL IF WHITE SMOKE COMES OUT OF THE MUFFLER ON FIRST OPERATION.**
- ! **DO NOT STAND BEHIND THE MUFFLER ON FIRST OPERATION.**
- ! **DO NOT USE AUTOMOTIVE WHEEL CLEANERS OR ANY CLEANING PRODUCTS WHICH CONTAIN ACIDIC ADDITIVES TO CLEAN AKRAPOVIČ EXHAUST SYSTEMS.**

BMW M6 E63/E64 Titanium exhaust system

Product code: S-BME63/4M6E

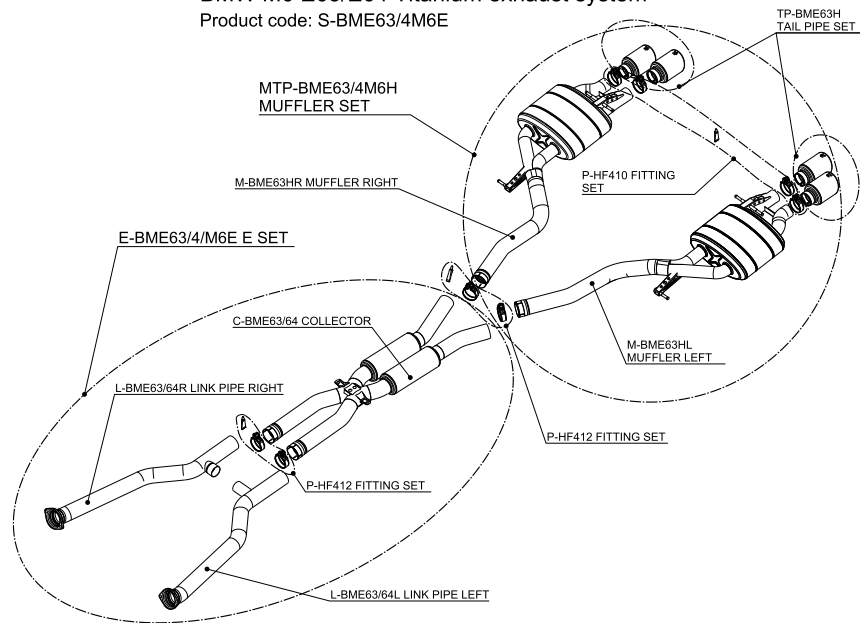

www.akrapovic.com



502428